





SMART 60



HD 76



HD 96

ENGINE	Kirloskar 4R 810T, TC EURO III, Diesel Engine Gross Power : 44.8 kW (60HP) @ 2400 RPM Gross Torque : 215 Nm@1600 RPM			Kirloskar 4R 1040, TC EURO III A, Diesel Engine Gross Power : 56.7 kW (76HP) @ 2200 RPM Max Torque : 300 Nm@1500 RPM			Kirloskar 4R 1040, TA2 EURO III A, Diesel Engine Gross Power: 71.6 kW (96 HP) @ 2200 RPM Max Torque: 377 Nm@1400 RPM		
TRANSMISSION	CARRARO synchro -shuttle transmission with integral torque converter			CARRARO synchro -shuttle transmission with integral torque converter			CARRARO synchro -shuttle transmission with integral torque converter		
STEERING	Power Steering			Power Steering			Power Steering		
ELECTRICALS	12V Battery System (90 Ah)			12V Battery System (130 Ah)			12V Battery System (180 Ah)		
TYRES	FRONT	2 WD	- 9 x 16 - 16 PR	FRONT	2 WD	- 9 x 16 - 16 PR	FRONT	2 WD	- 9 x 16 - 16 PR
		4 WD	- 12.5/80 x 18 - 12 PR		4 WD	- 12.5/80 x 18 - 12 PR		4 WD	- 12.5/80 x 18 - 12 PR
	REAR	Industrial	- 14 x 24 - 16 PR	REAR	Industrial	- 16.9 x 28 - 12 PR	REAR	Industrial	- 16.9 x 28 - 12 PR
		Heavy Duty	- 14 x 24 - 20 PR		Heavy Duty	- 14 x 25 - 20 PR		Heavy Duty	- 14 x 25 - 20 PR
SPEED	Forward max 30 Km/Hr Reverse max 9.3 Km/Hr			Forward max 40Km/Hr Reverse max 9.3 Km/Hr			Forward max 40Km/Hr Reverse max 9.3 Km/Hr		
HYDRAULICS	Smart Technology hydraulics : 2900 psi (200 bar) Pump O/P: 110 LPM@2400 RPM			Smart Technology hydraulics : 3335 psi (230 bar) Pump O/P: 113 LPM@2200 RPM			Smart Technology hydraulics : 3335 psi (230 bar) Pump O/P: 134 LPM@ 2200 RPM		
WEIGHT	6720 Kgs with Standard GP Bucket option			7850 Kgs with Standard GP Bucket option			8150 Kgs with Standard GP Bucket option		
CAPACITIES		<i>System</i>	<i>Service</i>		<i>System</i>	<i>Service</i>		<i>System</i>	<i>Service</i>
	Hydraulic Tank	115 Ltr	100 Ltr	Hydraulic Tank	120 Ltr	100 Ltr	Hydraulic Tank	120 Ltr	100 Ltr
	Fuel Tank	115 Ltr	-	Fuel Tank	115 Ltr	-	Fuel Tank	115 Ltr	-
	Engine Coolant	17 Ltr	15 Ltr	Engine Coolant	17 Ltr	15 Ltr	Engine Coolant	17 Ltr	15 Ltr
	Engine Oil	10 Ltr	10 Ltr	Engine Oil	12 Ltr	12 Ltr	Engine Oil	12 Ltr	12 Ltr
	Transmission	19.5 Ltr	16 Ltr	Transmission	19.5 Ltr	16 Ltr	Transmission	19.5 Ltr	16 Ltr
	Rear Axle	17 Ltr	17 Ltr	Rear Axle	17 Ltr	17 Ltr	Rear Axle	17 Ltr	17 Ltr
	4WD Front Axle	8 Ltr	8 Ltr	4WD Front Axle	8 Ltr	8 Ltr	4WD Front Axle	8 Ltr	8 Ltr
OPTIONS	Ditch Cleaning Bucket Square Hole Bucket Rock breaker Ripper tooth Trench bucket Taper Ditching bucket						Multipurpose 6 in I bucket Telescopic Dipper		



HD 100

DIMENSIONS

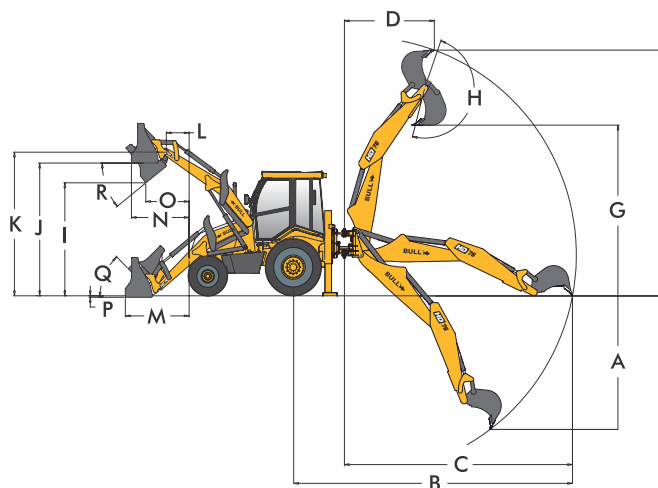

WORLD'S BEST COMPONENTS

Sourced from world's leading manufacturers.

PERKINS 1104D-44TA, EU NRMM 97 / 68 / EC EURO III A
Gross Power: **74.5 kW (100 HP) @ 2200 RPM**
Max Torque: **410 Nm@1400RPM**

ZF Power Shift transmission with integral torque converter

Power Steering

12V Battery System (180 Ah)

FRONT **2 WD** - 9 x 16 - 16 PR
 4 WD - 12.5/80 x 18 - 12 PR
REAR **Industrial** - 16.9 x 28 - 12 PR
 Heavy Duty - 14 x 25 - 20 PR

Forward max **37 Km/Hr**
Reverse max **22 Km/Hr**

Smart Technology hydraulics : **3335 psi (230 bar)**
Pump O/P: **145 LPM@2200 RPM**

8200 Kgs with Standard GP Bucket option

	System	Service
Hydraulic Tank	120 Ltr	100 Ltr
Fuel Tank	115 Ltr	-
Engine Coolant	17 Ltr	15 Ltr
Engine Oil	10 Ltr	10 Ltr
Transmission	19.5 Ltr	16 Ltr
Rear Axle	17 Ltr	17 Ltr
4WD Front Axle	8 Ltr	8 Ltr

AC Cabin | Loader Booster bucket with 12' 98" dump height

LOADER PERFORMANCE		60HP	76HP	96HP	100HP
Standard GP Bucket Capacity		1 cu.m	1.1 cu.m	1.1 cu.m	1.2 cu.m
I	Dump Height	2.96 m	2.96 m	2.96 m	2.96 m
J	Load Over Height	3.39 m	3.39 m	3.39 m	3.39 m
K	Pin Height	3.61 m	3.61 m	3.61 m	3.61 m
L	Pin Forward Reach	0.42 m	0.42 m	0.42 m	0.42 m
M	Reach at Ground	1.47 m	1.47 m	1.47 m	1.47 m
N	Reach at full height	1.28 m	1.28 m	1.28 m	1.28 m
O	Reach at full Height bkt Dumping	0.89 m	0.89 m	0.89 m	0.89 m
P	Below ground level DIG Depth	0.1 m	0.1 m	0.1 m	0.1 m
Q	Roll back at Ground	49°	49°	49°	49°
R	Dump Angle	45°	45°	45°	45°
Bucket Break-out Force		7178 Kgf	8183 Kgf	8183 Kgf	8793 Kgf
Loader Arm Break-out Force		4606 Kgf	5251 Kgf	5251 Kgf	5642 Kgf
Pay Load		1560 Kgf	1800 Kgf	1800 Kgf	2000 Kgf

	EXCAVATOR PERFORMANCE	60 HP		76 HP		96 HP		100 HP	
		Retraction STD	Telescopic Dipper (option)	Retraction STD	Telescopic Dipper (option)	Retraction STD	Telescopic Dipper (option)	Retraction STD	Telescopic Dipper (option)
	Standard Bucket Capacity	0.23 cu.m		0.27 cu.m		0.27 cu.m		0.27 cu.m	
A	Maximum DIG depth	3.56 m	4.60 m	5.59 m	4.60 m	5.59 m	4.60 m	5.59 m	
B	Reach Ground Level to Rear wheel center	6.32 m	6.80 m	7.91 m	6.80 m	7.91 m	6.80 m	7.91 m	
C	Reach at Ground level to slew center	5.10 m	5.50 m	6.60 m	5.50 m	6.60 m	5.50 m	6.60 m	
D	Reach at full height to slew center	2 m	2.85 m	3.56 m	2.85 m	3.56 m	2.85 m	3.56 m	
F	Maximum working height	5.40 m	5.92 m	6.77 m	5.92 m	6.77 m	5.92 m	6.77 m	
G	Maximum Load over Height	3.74 m	4.14 m	5.02 m	4.14 m	5.02 m	4.14 m	5.02 m	
H	Bucket Rotation power	200°		188°		188°		188°	
	Bucket Tear out force	5610Kgf		6072 Kgf		6072 Kgf		6392 Kgf	
	Dipper Tear out force	2200 Kgf		3150 Kgf		3150 Kgf		3316 Kgf	

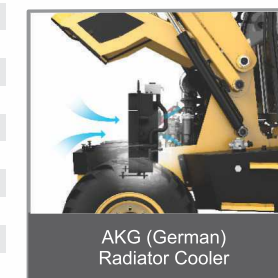
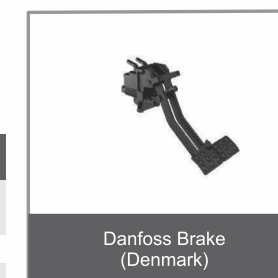

MULTIPLE BUCKET OPTIONS



SALIENT FEATURES

All machines come with advanced features that enhance their performance, productivity and reliability to the highest level

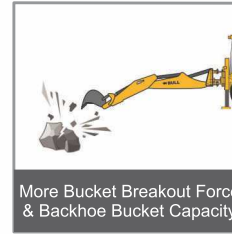

More Bucket Breakout Force & Backhoe Bucket Capacity



Heavy Weight Champion
8000 Kg
(550 Kg More Weight)



Most fuel efficient backhoe
in the world in its class*



The Tallest Dumping Backhoe
Loader in the World



Powder Coating : Scratch
Resistant Painting

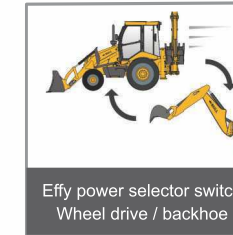

Effy power selector switch
Wheel drive / backhoe

EASY TO MAINTAIN AT LOW COST

An Operator friendly machine that facilitates and alerts the operator for regular maintenance.



Engine high temperature
Warning Alarm



Integrated oil filter with
Breather



Front Opening
Bonnet



Single layer Radiator/
Cooler: Easy to clean

WORLD CLASS CABIN COMFORT

Incorporated with features for the practical needs of the operator for uninterrupted fatigue free working for longer hours.

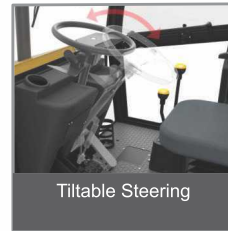

Tilttable Steering



60/76/96 HP
Forward reverse Switch



A/C Option



Joystick with
Selector Switch

Our other range of TA products

India's No.1
Tractor Attachments



BULL MACHINES PVT.LTD,
Trichy Road, Coimbatore. INDIA
email: sales@bullmachine.com
exports@bullmachine.com

Dealer